

FEATURES

- High-speed USB 2.0 device, USB 3.0 compatible
- Two 1MHz 16-bit A/D converters for 2MHz aggregate sampling rate
- Analog and digital inputs acquired simultaneously
- 4k sample FIFO (shared by all inputs)
- Per channel software selectable ranges of 0-1V, 0-2V, 0-5V, 0-10V, $\pm 1V$, $\pm 2V$, $\pm 5V$, $\pm 10V$
- Eight digital I/O's (four inputs & four high-current outputs)
- High retention USB type B connector for vibration-proof, worry-free communications
- Alternate USB micro-fit header can be used to reduce board footprint in embedded applications
- Small rugged steel industrial enclosure

FACTORY OPTIONS

- OEM version (board only) features PC/104 module size and mounting compatibility
- Extended temperature (-40° to $+85^{\circ}C$)
- External power
- Screw terminals for power input provide high retention connection
- LVTTTL DIO lines
- RoHS compliant product



FUNCTIONAL DESCRIPTION

The USB-AI16-2A is a high-speed USB 2.0 device designed for many applications including laboratory and semiconductor fab signal analysis. This product is a USB-based Analog to Digital (A/D) converter board that features two single-ended 16-bit analog inputs with software selectable input ranges, per channel. The board samples each A/D at 1MHz, simultaneously, for an aggregate speed of 2MHz.

Also provided are four general purpose digital inputs and four high-current digital outputs. The inputs and outputs can be configured for 10k ohm pull-up or pull-down resistors (inputs and outputs are separately configurable).

The A/D conversion process is initialized by software control and can be started either by software command or digital input trigger via the right angle I/O header connector. Two status signals are provided at the I/O header; one indicates conversions are enabled; the other indicates the board's FIFO is almost full. Each sample acquired includes both of the analog input channels and the four digital inputs simultaneously. All data acquired by the board is time stamped with μ second resolution.

The board is designed to be used in rugged industrial environments but is small enough to fit nicely onto any desk or testing station. The module is PC/104 sized (3.550 by 3.775") and ships standard inside a steel powder-coated enclosure with an anti-skid bottom.

OEM USB/104 FORM FACTOR

The OEM (board only) version is perfect for a variety of embedded applications. What makes the OEM option unique is that its PCB size and pre-drilled mounting holes match the PC/104 (3.550 by 3.775 inches) form factor (without the bus connections). This ensures easy installation using standard standoffs inside most enclosures or systems. For embedded OEM applications, a miniature USB input header is provided in parallel with the type B connector.

ACCESSORIES

We provide a variety of cables, terminal boards and mounting provisions such as the MP104-DIN for convenient DIN-Rail mounting.

SOFTWARE

The USB-AI16-2A utilizes a high-speed custom function driver optimized for maximum continuous data throughput of 4 MB/s that is hundreds to thousands of times faster than the USB human interface device (HID) driver used by some competing products. This approach maximizes the full functionality of the hardware along with capitalizing on the advantage of high-speed USB 2.0. The module is supported for use in most USB supported operating systems and includes a free Linux and Windows compatible software package. This package contains sample programs and source code in C#, Delphi and Visual C++ for 32-bit and 64-bit Windows. Also incorporated is a graphical setup program in Windows. Third party support includes a Windows standard DLL interface usable from the most popular application programs, and includes LabVIEW VIs. Embedded OS support includes the family of Windows Operating Systems including IoT.

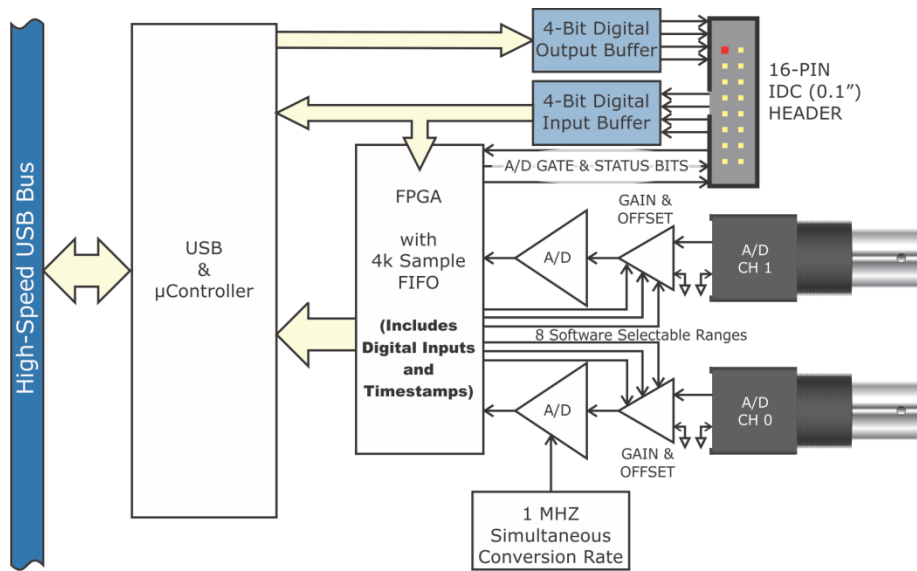

BLOCK DIAGRAM

SPECIFICATIONS

Analog Inputs

Number: 2, Single-ended
 ADC Type: Successive Approximation
 Sample Rate: 2MHz aggregate across both channels (1MHz each simultaneous)
 Resolution: 16-Bit
 Ranges: 0-1V, 0-2V, 0-5V, 0-10V
 $\pm 1V$, $\pm 2V$, $\pm 5V$, $\pm 10V$ software ranges per channel

Impedance: 1M Ω
 Data FIFO: Width: 16-bit
 Depth: 4k samples

Digital I/O 4 inputs, 4 outputs

Logic Levels	5V	
Low Inputs	$\leq 1.5V$	$\leq 2\mu A$
High Inputs	$\geq 3.5V$	$\leq 2\mu A$
Low Outputs	$\leq 0.55V$	32mA
High Outputs	$\geq 3.8V$	32mA

Logic Levels	3.3V LVTTTL Option	
Low Inputs	$\leq 0.8V$	$\leq 2\mu A$
High Inputs	$\geq 2.0V$	$\leq 2\mu A$
Low Outputs	$\leq 0.55V$	24mA
High Outputs	$\geq 2.4V$	24mA

Environmental

Operating Temp: Commercial: 0° to 70° C
 Industrial: -40° to +85° C
 Storage Temp: -40° to +85° C
 Humidity: 5%-95%, non-condensing
 Board Dimension: 3.550 x 3.775 inches

Power

+5VDC ~415 mA typical, no-load*

*+5VDC from the USB bus.

USB host controllers provide a max of 500mA in most desktop environments. This gives you 85mA available (500mA - 415mA = 85mA) to divide amongst the digital output buffered lines. Optional AC/DC adapter can be ordered ("-PR" option) if USB can't supply the full 500 mA.

ORDERING GUIDE

USB-AI16-2A High-Speed, 2-Channel Analog Input Module with rugged steel enclosure & 6 foot USB 2.0 cable

OPTIONS:

-OEM Board only (no enclosure)
 -T Ext. Temp. Operation -40 to +85 °C
 -LVTTTL 3.3V signaling on DIO lines
 -PR Power adapter, AC/DC 5V regulated
 -ST Screw terminals for external power
 -RoHS Compliant product

Accessories

UTBK-16 16-Pin female to screw terminal board



CAB-BNC-6 Standard 6-foot co-axial cable, male BNC connectors

CAB-BNC-CLIP 3-foot co-axial BNC to minigrabber test clip cable

MP104-DIN DIN-rail mounting plate

